



**MODEL** KAWASAKI Z125 / NINJA 125

**YEAR** 2019 -->

**LINE** SLIP ON

**MUFFLER** DELTA RACE

**SCHEMATIC**

**ELENCO PARTI / PARTS LIST**

#	QTÀ / QTY	DESCRIZIONE / DESCRIPTION	CODICE / CODE
1	1	DB killer / DB killer	50.DK.146.0
2	1	Silenziatore / Muffler	DELTA RACE
3	1	Staffa / Bracket	50.SS.1131.0
4	2	Rondella di sicurezza / Safety washer	50.73.604.1
5	2	Vite M8 x 16 / Screw M8 x 16	50.73.098.1
6	1	Dado M10 flangiato / Flanged nut M10	50.73.332.1
7	1	Rondella in alluminio nera / Black aluminium washer	50.73.330.1
8	1	Vite M10x60 / Screw M10x60	50.73.135.1
9	1	Db Killer / DB killer	50.DK.081.0
10	1	Tubo di raccordo / Link pipe	9773K048S2
11	1	Fascetta Ø 36/39 mm / Pipe clamp Ø 36/39 mm	50.FA.002.1
12	1	Molla media / Middle spring	50.73.359.1
13	1	Tubo in gomma per molla / Rubber pipe for spring	50.73.210.1

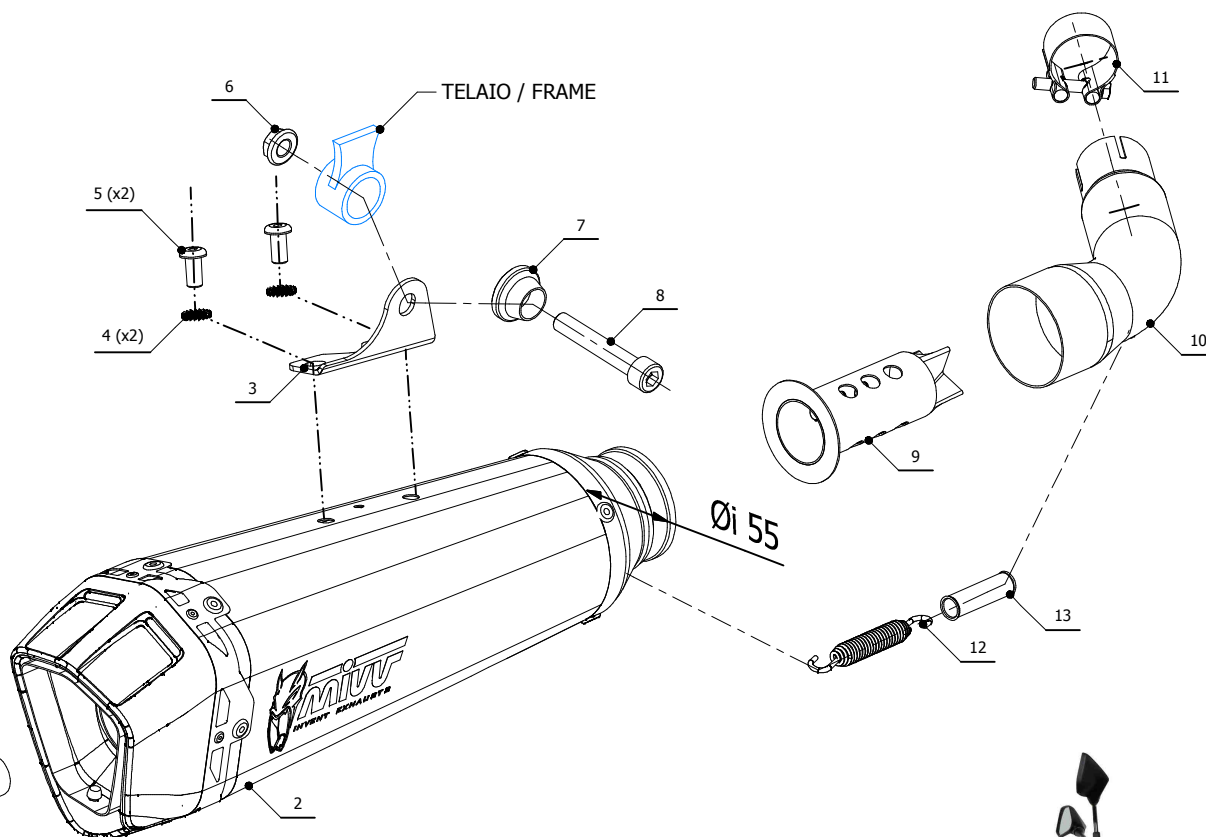

**OPTIONAL PART**

TUBO NO KAT - NO KAT PIPE

**K.048.C1**



Monta con silenziatore originale e con scarichi MIVV  
It fits with original silencer and with MIVV exhausts

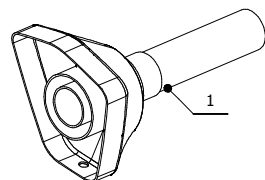

**ATTENZIONE:** La rimozione del riduttore di rumore è considerata una manomissione dell'impianto di scarico che comporta la perdita dell'omologazione per utilizzo stradale e della garanzia prodotto. In caso di rimozione del riduttore di rumore l'impianto di scarico è in configurazione "racing" e può essere utilizzato solo in pista.

**WARNING:** Removal of the noise reducer is considered a tampering of the exhaust system which entails the loss of both the type approval for road use and the product warranty. In case of removal of the noise reducer the exhaust system is in "racing" configuration and can be only used on track.

**APPLICAZIONI / APPLICATIONS**

CODICE / CODE	SILENZIATORE / MUFFLER	TUBO / PIPE
K.048.LDRX	INOX (COPPA CARBONIO) / ST. STEEL (CARBON CAP)	INOX / ST. STEEL
K.048.LDRB	STEEL BLACK	