

ELENCO PARTI / PARTS LIST

#	QTÀ / QTY	DESCRIZIONE / DESCRIPTION	CODICE / CODE
1	1	DB killer / DB killer	50.DK.020.0
2	1	Silenziatore / Muffler	GP
3	1	Protezione in gomma per staffa / Rubber protection for bracket	50.73.040.1
4	1	Staffa / Bracket	50.SS.001.0
5	1	Dado 8 MA flangiato / Flanged nut 8 MA	50.73.052.1
6	1	Rondella in alluminio / Aluminium washer	50.73.063.1
7	1	Vite M8x50 / Screw M8x50	50.73.074.1
8	1	Tubo di raccordo / Link pipe	9773Y013S2
9	1	Fascetta Ø 56/59 mm / Pipe clamp Ø 56/59 mm	50.FA.009.1
10	1	Molla / Spring	50.71.080.1
11	1	Tubo in gomma per molla / Rubber pipe for spring	50.73.049.0

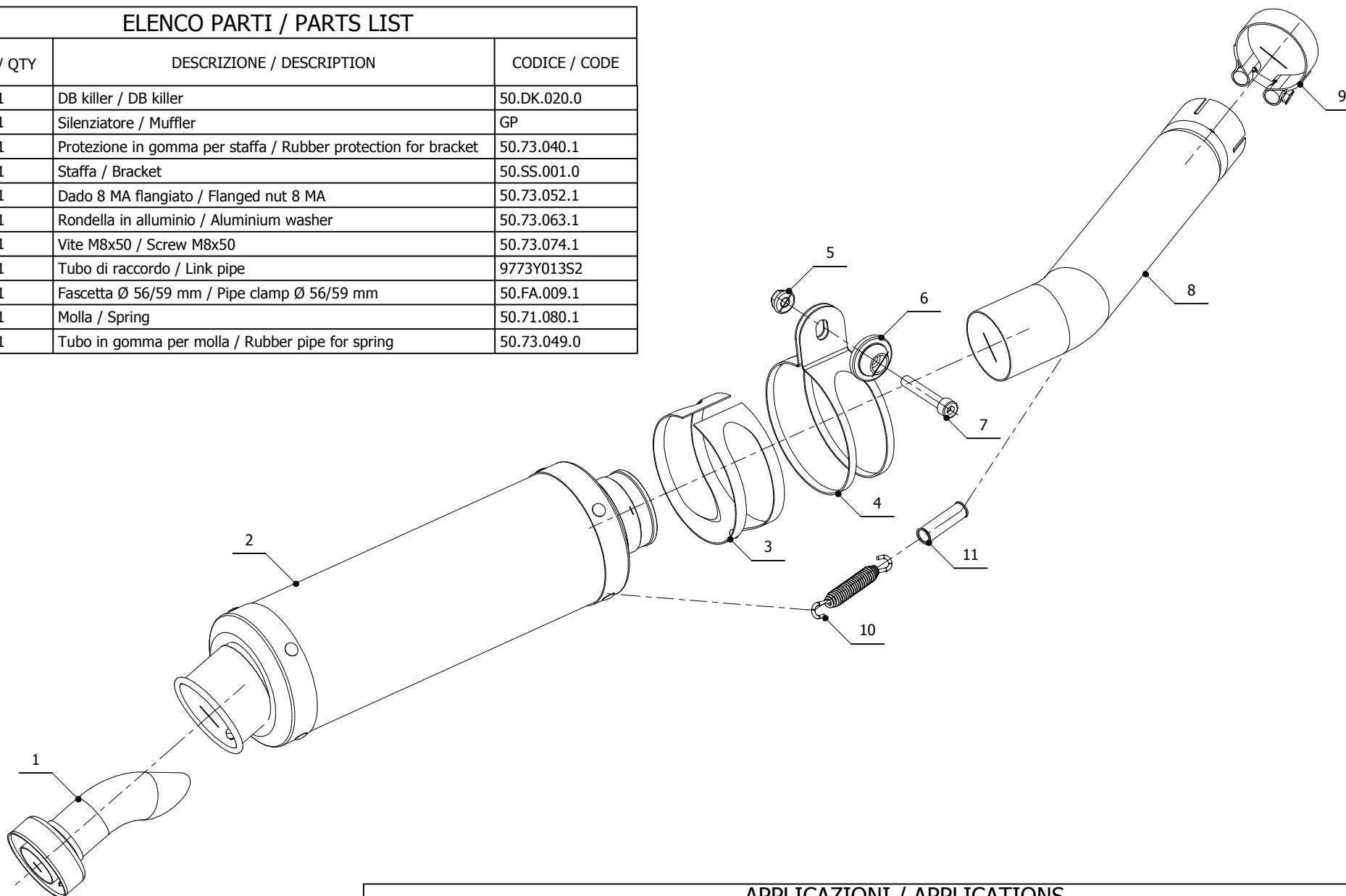

APPLICAZIONI / APPLICATIONS

CODICE / CODE	TUBO / PIPE	SILENZIATORE / MUFFLER	FASCETTA / CLAMP	CODICE OMOL. / HOMOL. CODE
74.Y.013.LXS	INOX / ST. STEEL	INOX / ST. STEEL	INOX / ST. STEEL	ME008 e9 1176



**CERTIFICATO DI OMOLOGAZIONE
HOMOLOGATION CERTIFICATE
ABE-BESCHEINIGUNG
CERTIFICAT D'HOMOLOGATION**

Tipo Silenziatore Silencer Type Auspuffsystem Typ Type de silencieux	Nr. Omologazione Homologation Nr. EU. Genehmigungsnummer Numéro d'homologation	Tipo veicolo Vehicle Type Fahrzeugstyp Type de véhicule	Modello Veicolo Vehicle Model Fahrzeugmodell Model de véhicule
ME008	e9 1176	RK000, RK001, RKC00, RKA00, RKB00, RKE00 R12 0307 A, R12 0303 A, R12 0407A R1ST RHP2 E8GS 0219A, E8GS 218A R21 0429 E8ST, E8ST 0217A PC35 ZX636B ZX600K ZR750, ZR750J, ZR750L ZXT00, ZX1000-C, ZXT00E, ZXT00J ZX600R WVB2, CE1, WVCV WVB3, CF1, WVCW WVB6 WVB1 C5, C511 RN01, RN04, RN09 RJ02 RJ05, RJ09 RN06 - RN14 LS LP LP, LPG0	APRILIA RSV4, RSV4 R, FACTOY, APRC BMW R 1200 GS BMW R 1200 R BMW HP2 BMW F 800GS / F 650GS BMW R 1150 R F 800 R HONDA CBR 600 F/FS KAWASAKI ZX6R (636) KAWASAKI ZX6RR (600) KAWASAKI Z750 KAWASAKI ZX10R KAWASAKI ZX-6R SUZUKI GSX 600R SUZUKI GSX 750R SUZUKI GSX 1000R SUZUKI DL 650 V-STROM SUZUKI GSR 750 YAMAHA YZF R1 YAMAHA FZS 600 - FAZER YAMAHA YZF R6 YAMAHA FZS 1000 - FAZER MOTO GUZZI GRISO MOTOGUZZI BREVA 1100 MOTOGUZZI BREVA 1200

Il suddetto impianto di scarico, da noi prodotto, è conforme con la:
 The above exhaust system is in compliance with the:
 bestätigt, dass og von uns hergestelltes Auspuffsystem, der:
 Le système d'échappement susnommé est en conformité avec la :

***EC-Directive 97/24/EC Chapter 9
entspricht***

