

Before installing this product, check the contents of the kit. If anything is missing, please contact an Öhlins dealer.

#### Kit Contents

	Part No.	Pcs.
Steering damper	02261-20	1
Bracket assy	02230-09	1
Bolt M8x40	01046-21	1
Spacer	02238-05	1
Teflon spacer	02259-01	1
Öhlins Sticker	00192-01	2
Owner's Manual	07261-01	1

Please note that during storage and transportation, especially at high ambient temperature, some of the oil and grease used for assembling may leak and stain the packaging. This is in no way detrimental to the product, wipe off the excessive oil/grease with a cloth.

#### ⚠ Warning!

Before installing this product, read the Öhlins Owner's Manual. The shock absorber is an important part of your vehicle and will affect the stability.

Öhlins products are subject to continuous improvement and development, therefore, although these instructions include the most up-to-date information available at the time of printing, minor updates may occur. To find the latest information contact your Öhlins distributor. Please consult your Öhlins dealer if you have any questions regarding the contents in this document.

© Öhlins Racing AB. All rights reserved. Any reprinting or unauthorized use without the written permission of Öhlins Racing AB is prohibited.

Öhlins Racing AB  
Box 722  
S-194 27 Upplands Väsby, Sweden  
Phone +46 8 590 025 00  
fax +46 8 590 025 80

Part no. SD 027\_0  
Issued 2009-04-14

## Steering Damper for Yamaha R1

# SD 027

## Mounting Instructions



**⚠ Warning!**

It is advisable to have an Öhlins dealer install the steering damper.

When installing, consult your Vehicle Service Manual.

**1**

Put the motorcycle on a workstand so that the front wheel barely touches the ground.



**⚠ Warning!**

Make sure the vehicle is securely supported so that it will not tip.

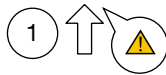
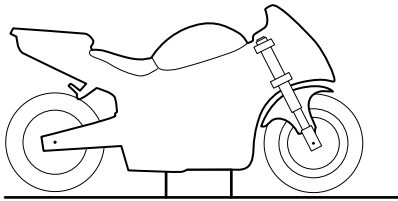

**2**

Remove the original steering damper. See the Vehicle Service Manual for advice.

**3**

Install the bracket assembly (02230-09) on the Öhlins steering damper.

**4**

Install the Öhlins steering damper to the original brackets. Use bolt (01046-21), original nut and spacer (02238-05) for the end eye bracket on the front fork leg. Use original bolt and washers to the frame bracket. Install the teflon spacer between the Öhlins bracket and the lower original washer.

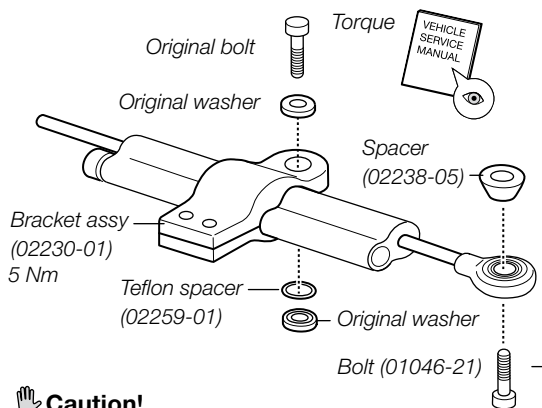

**⚠ Caution!**

Ensure that there is no clearance problem when turning to the left and the right end positions. Make sure that the steering damper is not used as a stop.

**⚠ Caution!**

Make sure that all screws are tightened to the correct torque and that nothing fouls or restricts movement of the steering damper.

**5**

Adjust the bracket assembly so that the steering damper stroke is equal in each steering direction.

**6**

Tighten the bolts to correct torque, see figure.

**⚠ Warning!**

Before riding, always make sure that the basic settings made by Öhlins are according to recommended Set-up Data. Read about adjustments and setting up in the Öhlins Owner's Manual before you make any adjustments. Contact an Öhlins dealer if you have any questions about setting up the steering damper.

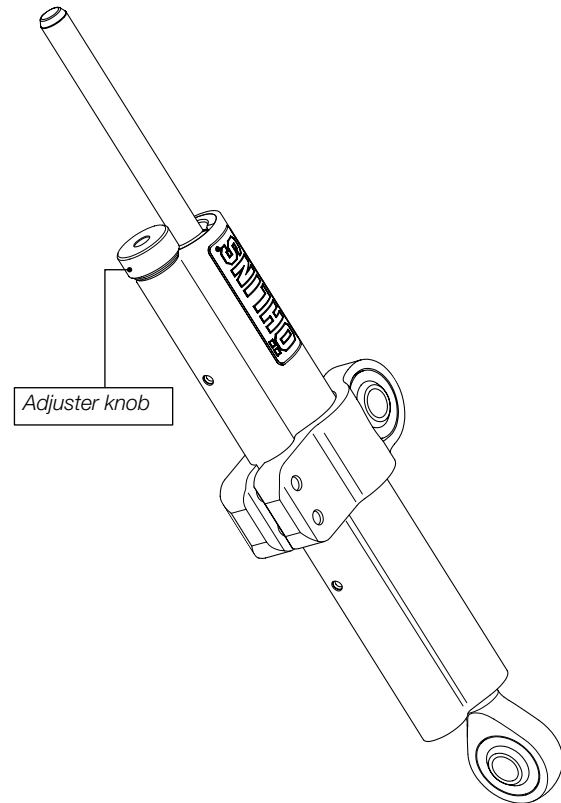

## Set-up Data

Recommended set-up      10 clicks